

Sergio C. Ooijens

Adding Dynamics to the Camp Model for the Calculation of Overflow Losses

Abstract

The sedimentation of fine sands in the hopper of a trailing suction hopper dredger (TSHD) forms an essential part of the dredging process. Until now, in models the sedimentation process mainly has been described as being (quasi-)static. However in order to understand the process and to be able to optimise the dredging time with controllable parameters, dynamics should be analysed and described.

The Camp model was improved by Vlasblom and Miedema¹, which provided a tool to describe overflow losses as a function of the incoming flow, grain sizes, concentration and the geometry of the volume of mixture in the hopper. However, it was still a steady-state model. When analysing the dynamics in the settlement process, a quasi-static approach cannot explain all the changes in the overflow losses. In this article dynamics relations are introduced based upon a simple mass and volume balance and then implemented in the Camp model by manipulating the input, but without changing the steady-state model.

The described dynamic relations were implemented in a simulation and compared with onboard measurements from the TSHD Amsterdam. This resulted in a remarkable improvement in the correlation between the onboard measurements and the simulation.

This article was written with the cooperation of Prof W.J. Vlasblom, Chair of Dredging Technology at Delft University of Technology, and Engineers Ronald A. van der Hout and Maurits den Broeder, both of Ballast Nedam Dredging, The Netherlands.

Introduction

When dredging fine sands with a TSHD the overflow losses form an essential part of the process. A good description of the sedimentation process is needed, not only to improve calculations of the dredging time,

but also for a better understanding of the process itself. In the past years, a few models have been developed to estimate and predict these losses. Some of these are more mathematical models (i.e. De Groot), others more basic (i.e. Camp).

At the WODCON XIV, Vlasblom and Miedema¹ presented an improved version of the Camp model, that takes into account the influences of most of the important parameters and neglects all local processes. This model is easy to understand and does not need sensitive calculations. Disadvantages are that the model assumes a steady-state situation in which parameters like concentration, flow, and the volume of the mixture in the hopper are assumed to be constant. However, during test performed by the TU Delft and from experience onboard, it became clear that the parameters change during loading and that dynamics play an important role in the sedimentation process. These dynamic changes not only concern the increase in the height of the bed of sand, but also changes in the flow and concentration in the hopper during loading.

The goal of this article it is not to give an exact calculation method predicting the overflow losses, but to describe the dynamics on the basis of the Camp model. It seems that when adding even simple dynamics to this steady-state model, a lot of changes in the overflow losses can be accounted for and the correlation between model and measurement becomes remarkably higher.

First the influences on the overflow losses in general will be described. Also a short description of the Camp model will be given. Then to understand the introduction of dynamics to this model, a qualitative description of the changes in the parameters during dredging will be given, followed by a more mathematical analysis of the influence of the parameters to quantify the changes. Finally, some examples will be shown in which a simulation based on the derived relations for the dynamics and the Camp model, are compared with onboard measurements.

OVERFLOW LOSSES

The efficiency of the hopper is defined by the fraction of the incoming sand that settles in the hopper (bzg). However, the primary consideration is the fraction that does not settle and flows overboard: the overflow losses (ov). In literature, these losses are defined by the ratio between outgoing concentration and incoming concentration (assuming incoming and outgoing flow are equal), or more correctly, the outgoing and incoming production.

$$ov = \frac{P_{bruto} - P_{netto}}{P_{bruto}} = \frac{Cv_{out} \cdot Q_{out}}{Cv_{in} \cdot Q_{in}} \quad \text{Eq. 1}$$

Equation 1 could give the impression that there is a direct relation between incoming and outgoing production. However, as will be described later on, the influence of a change in incoming flow and concentration on the total production cannot be described momentarily, but has to be evaluated over a certain period of time.

Variables of influence

The most important parameters in the hopper sedimentation process can be found when analysing the settling velocity (time to settle) and the horizontal velocity (time to reach the overflow).

The settling velocity is mainly determined by the size of the grains (d), as shown in equation 2, describing the settling velocity in calm and clear water. However the sand will never consist of one grain size. So, the settlement velocity of every fraction of the grain size distribution (d_{50} , cu) has to be taken into account.

$$v = \sqrt{\frac{4 \cdot g \cdot (\rho_s - \rho_w) \cdot d \cdot \psi}{3 \cdot \rho_w \cdot C_d}} \quad \text{Eq. 2}$$

The settlement is also influenced by a few other parameters.

First of all, the water contains a concentration (Cv) of sand particles, which induces the effect of hindered settlement. When grains settle to the bottom, water is pushed out. This causes a current in the other direction (upwards) and reduces the settling velocity. With an increasing concentration not only more water is replaced, but at the same time it will be harder for the replaced water to flow in the opposite direction, causing an even lower settlement velocity. The corrected velocity was defined by Richardson and Zaki¹ as:

$$v_c = (1 - Cv)^\beta \cdot v \quad \text{Eq. 3}$$



Sergio Ooijens (right) receiving the IADC Student Award from Mr Hans van Diepe on behalf of the IADC.

The IADC “Most Promising Student” Award

To stimulate technical universities worldwide to increase their interest in the dredging industry in general and to improve the quality of their students in dredging-related technologies in particular, the IADC has instituted an awards programme for the most interesting final theses on dredging-related subjects. Each award carries with it a prize of US\$500, a certificate of recognition, and the possibility of publication in *Terra et Aqua*.

This year a student award was granted to Sergio C. Ooijens at the recommendation of Prof Willem Vlasblom of the Delft University of Technology, The Netherlands. The award was officially presented by Mr Hans van Diepen (Royal Boskalis) on behalf of the IADC at a special ceremony. Mr Ooijens graduated as a mechanical engineer in January 1999, and did his thesis at Ballast Nedam Dredging on the loading of a hopper dredger. His paper is published here with their permission.

Where as β is a number greater than 1 depending on the Reynolds number of the grain.

Secondly, the mixture in the hopper is not calm, so the influence of the turbulence in the hopper should be taken into account. This turbulence is mainly caused by the velocity of the mixture, which can be described as a function of the flow (Q) and the free volume (H, L, B) and which depends on an internal flow.

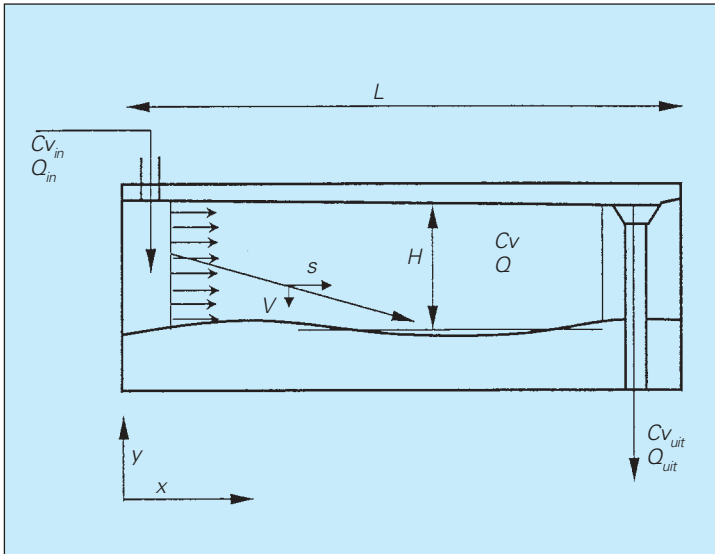

Figure 1. Parameters in the hopper.

When assuming a uniform velocity profile, the horizontal velocity can be described as a function of the average flow (Q) and the free volume (V=H* L*B) of the mixture in the hopper.

Camp: a steady-state model

At the WODCON XIV, Vlasblom and Miedema presented an adjustment to the Camp model. An advantage of this Camp model is that it considers the hopper as a 'black box', and thus does not take into account the rather complicated local processes.

The adjusted model is based upon a ratio of time a grain needs to settle and time a grain needs to flow through the hopper. Starting from the principle of a uniform distribution of the incoming concentration over the height at the entrance of the hopper (Figure 1), a grain is assumed to have settled when the time to settle from a certain height (settlement time) is lower than the time needs to reach the overflow (residence time). The calculated settling velocity is corrected with hindered settlement based upon the incoming concentration. The calculated efficiency is then corrected for a turbulence efficiency depending on the incoming flow and the geometry of the volume of mixture.

The overflow losses are the sum of the losses of all fractions of the grain size distribution. Now, overflow losses can be described as a function of the grain size, the average flow (Q_{ave}), concentration in the hopper (C_v), the height and the surface in the hopper and the bed on the bottom (H).

$$ov = f(C_v, Q_{ave}, H, d_{50}, cu) \tag{Eq. 4}$$

It is important to acknowledge the restrictions and assumptions to the model. Local processes, like erosion and local flow and concentration, are neglected

in this model. Although these processes are essential for a good understanding, they are still difficult to describe.

Besides this, the model assumes a steady state (this means the history of the process does not influence its current state) in which the concentration in the hopper, the average flow and the height of the volume of mixture are constant, which in real-time dredging is never the case.

DYNAMICS

Now that the main parameters of influence are known, one can analyse their change in time. Before introducing these dynamics into this model one should consider the development of the process in time, for example by dividing the process in different loading stages.

Stages of loading

1. Beginning of the dredging

When a TSHD starts dredging, the hopper is loaded with some residue and some water. Until the overflow (maximum volume) is reached there will be no outgoing flow and thus the overflow losses are equal to zero. More important is the low average velocity in the hopper creates a relatively good condition for the grains to settle. Consequently, the average concentration in the hopper will be relatively low when the overflow is reached.

2. CVS (Constant Volume System)

When the overflow is reached one will try to continue loading with a maximum volume (CVS). This will mean that there is a constant total volume. After some time, the incoming flow is equal to the average flow in the hopper and thus the outgoing flow.

Owing to the settlement, the volume of the bed of settled sand in the hopper will increase and thus the volume of mixture will decrease. With an equal volume but an increasing average density, the displacement of the ship will increase.

3. CTS (Constant Tonnage System)

Finally, when the maximum draught has been reached, the dredger will try to load with a maximum load in the hopper. Reducing the total volume can compensate the increase in weight owing to the loading of the relatively heavier sand. This displacement is constant when the volume is reduced with:

$$\frac{dV}{dt} = \left(1 - \frac{\rho_{in}}{\rho_{out}} \right) \cdot Q_{in} \tag{Eq. 5}$$

When the overflow efficiency is known, one can calculate the outgoing flow when loading with CTS as a function of the incoming (measured) parameters:

$$Q_{out} = Q_{in} \cdot \left(1 + C_{v,in} \cdot b z g \cdot \frac{\rho_s - \rho_w}{\rho_w} \right) \quad \text{Eq. 6}$$

The dredging will continue until the minimum volume or an optimal loading point has been reached.

Development of the overflow losses

Related to these different methods of loading are the changes in the overflow losses (Figure 2), which can be distinguished in four stages (when loading with a constant flow and concentration).

I. Before the overflow has been reached there is no outgoing flow. Consequently there are no overflow losses. In this phase there is a decreasing horizontal velocity in the hopper, which means a good sedimentation of the grains, so the average concentration of mixture in the hopper (C_v) will be relatively low (compared to the incoming concentration) when the overflow is reached.

II. When the overflow is reached a flow out of the hopper starts at the overflow and the velocity in the hopper will increase. The increasing average velocity will cause a decreasing settling efficiency. Owing both to this decrease and to the relatively higher incoming concentration, the average concentration in the hopper will slowly increase causing a decreasing settling velocity and thus an increase in the overflow losses.

III. After these changes in the average flow and concentration in the hopper a quasi-static phase emerges in which (when the incoming flow and concentration and the total volume stay constant) only the volume of mixture and thus the height to settle and the horizontal velocity will slowly increase. Since the overflow losses (in this model) are quite insensitive to this parameter up until the time the scouring velocity is reached, the overflow losses are quite constant in this phase.

IV. When the free volume in the hopper decreases the horizontal velocity in the hopper will increase and scouring will dominate the settling process and the overflow losses will increase excessively.

Process and input dynamics

It is clear that the changes in the loading conditions have their influence on the overflow losses. When describing these changes one has to distinguish two types of dynamics:

- process dynamics, and
- input dynamics.

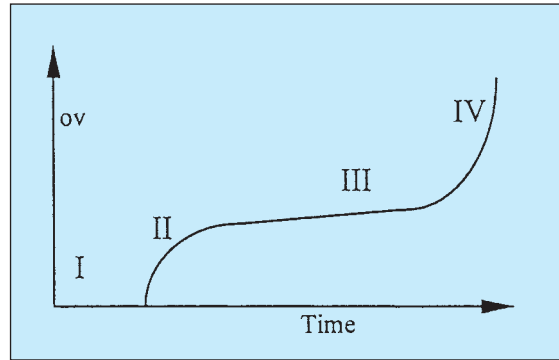

Figure 2. Phase in the overflow losses.

In this article process dynamics are defined as the changes that are caused by the *nature* of the process.

The main examples of these changes are:

1. Change in the height (H) of the mixture

The most logical change is the increase of the bed of sand owing to sedimentation and thus a decrease of the free volume of the mixture and the height of this volume (H). This volume will also decrease when loading with the Constant Tonnage System because of a decreasing total volume.

2. Change in the local and average velocity when the overflow is reached (Q)

When filling the hopper, the velocity will decrease over the length of the hopper (from the start until the overflow). The outgoing flow is induced by the height of water above the overflow, so a build-up of water above the overflow is needed for an outgoing flow. Thus when the overflow is reached, the volume and the outgoing flow will slowly increase until the outgoing and incoming flow are equal.

3. Change in the local and average concentration when the overflow is reached (C_v)

As described before the expectation is that the average concentration in the hopper is relatively low when the overflow is reached because of good settlement conditions.

4. Change in flow (Q) when changing from CVS to CTS

When changing to CTS the overflow will be lowered and the average flow will increase. For the change from CVS to CTS a build up of water will be needed too.

Input dynamics are the dynamics in the process as a result of a change in the input:

1. Changing the incoming flow (Q)

Adjusting the incoming flow will not effect the average flow in the hopper immediately; a build up in the height of the water at the overflow is needed to increase the outgoing flow. This build-up means increase in the total volume to increase the average flow.

List of symbols

β	coefficient for the hindered settlement	[-]
ν	cinematic viscosity	[m ² s ⁻¹]
ρ_{corr}	density corrected as input for simulation	[kg m ⁻³]
ρ_m	density of mixture in the hopper	[kg m ⁻³]
ρ_w	density of water	[kg m ⁻³]
ρ_s	density of solids (sand)	[kg m ⁻³]
ρ_{in}	density of incoming mixture	[kg m ⁻³]
ρ_{out}	density of outgoing mixture	[kg m ⁻³]
ρ_{bed}	density of the settled bed	[kg m ⁻³]
ψ	shape factor	[-]
τ	residence time	[-]
t	time	[s]
Δt	sample period / steptime	[s]
bzg	settlement efficiency	[-]
cu	grain size uniformity	[-]
d	grain size	[mm]
d_{50}	median of the grain size distribution	[mm]
n	sample number	[-]
ov	overflow losses	[-]
s	average horizontal velocity in the hopper	[m s ⁻¹]
u	horizontal velocity at the overflow	[m s ⁻¹]
v	settlement velocity	[m s ⁻¹]
v_c	corrected settlement velocity	[m s ⁻¹]
w	settlement velocity of a particle	[m s ⁻¹]
B	width of the hopper	[m]
C_v	model concentration in the hopper	[-]
$C_{v_{\text{in}}}$	incoming concentration	[-]
$C_{v_{\text{out}}}$	outgoing concentration	[-]
H	height of the bed of sand in the hopper	[m]
L	length of the hopper	[m]
Q	flow	[m ³ s ⁻¹]
Q_x	flow at position x in the hopper	[m ³ s ⁻¹]
Q_{in}	incoming flow	[m ³ s ⁻¹]
Q_{out}	outgoing flow	[m ³ s ⁻¹]
Q_{ave}	average flow	[m ³ s ⁻¹]
TDS	Tonnes Dry Solids	[tons = 1000 kg]
V	total volume	[m ³]
V_m	volume of mixture in the hopper	[m ³]
V_{bed}	volume of bed of sand in the hopper	[m ³]
V_{mix}	volume to flow through in the simulation	[m ³]

2. Change in the incoming concentration (C_v)

When the incoming concentration, as delivered by the draghead, is changed this will not directly influence the average concentration in the hopper.

3. Change in the grain diameter/grain distribution (d_{50} , cu).

During the dredging process the soil conditions and thus also the incoming grain size can change locally. It is quite hard to measure this grain size distribution on-line.

MATHEMATICAL ANALYSIS

Until now, the description of the dynamics has been qualitative. When quantifying the sedimentation process by considering the hopper as one system it is useful to make an input-output relation, based upon a simple mass balance (Eq. 7) and volume balance (Eq. 8):

$$\frac{dM(t)}{dt} = Q_{\text{in}}(t) \cdot \rho_{\text{in}}(t) - Q_{\text{out}}(t) \cdot \rho_{\text{out}}(t) \quad \text{Eq. 7}$$

$$\frac{dV(t)}{dt} = Q_{\text{in}}(t) - Q_{\text{out}}(t) \quad \text{Eq. 8}$$

The outgoing flow and concentration are a function of the hopper process. The incoming flow and concentration can be measured and are known.

Dynamics of the flow

A great deal of the dynamics seem to concern the changing average flow (Q) and concentration (C_v) in the hopper. The flow as an input to the Camp model is the average flow in the hopper, which changes in time influenced by the change in volume and change in incoming flow.

The flow in the hopper depends on local influences, but one can assume the main changes occur in the length of the hopper (x). Equation 9 shows that the impact of a change in the incoming flow takes place after a build-up in the local height and volume. This causes a difference between local flow and incoming flow.

$$Q_x = Q_{\text{in}} + \int_0^x \left(B \cdot \frac{dh(x)}{dt} \right) dx \quad \text{Eq. 9}$$

When all local processes are neglected, the average flow can be described as an average of the incoming and outgoing flow (Eq. 10). By making this assumption a part of the dynamics will be lost, but the problem will be enormously clarified.

$$Q_{\text{ave}} = Q_{\text{in}} + 0.5 \cdot \frac{dV}{dt} \quad \text{Eq. 10}$$

The outgoing flow depends on the height of the water at the overflow and is thus related to the total volume. An increase in the incoming flow (Q_{in}) has to cause an increase in the total volume (V) before causing an increase in the outgoing flow (Q_{out}). Analogous, when decreasing the volume by lowering the overflow, the flow will increase and eventually the volume will decrease.

Assuming the outgoing flow at the overflow can be described as a clear overflow weir, one can describe a dynamic relation between the average flow in the hopper and the incoming flow based upon a simple volume balance.

Dynamics of the concentration

So the dynamics in the flow cannot be described as being quasi-static. In practice however the variance in the overflow losses owing to the fluctuations in the concentration seems to be more important. In the analyses several concentrations are distinguished:

- *Incoming concentration* ($C_{v,in}(t)$): the concentration delivered by the draghead.
- *Outgoing concentration* ($C_{v,out}(t)$): the concentration at the overflow, which is a function of the hopper process.
- *Local concentration* $C_v(x,y,t)$: the local concentrations in the hopper. These will locally affect the settlement by the 'hindered settlement' effect.

The Camp model is not a function of the local concentrations, but of the incoming concentration in a steady state situation. Nevertheless, every change of concentration in the hopper, when not in a steady state situation, will have to be compensated in the input to the Camp-model. To describe the total effect of the local concentrations a model-concentration ($C_v(t)$) is introduced. This concentration is a fictive one based upon the incoming concentration and is used to describe the influence in the process.

There are two ways to make a simple model of the dynamics of the concentration as a parameter for the settling model and describe the change in concentration when the overflow is reached and when the incoming concentration changes:

- plug flow or
- ideal mixing.

For the first option, one can assume the incoming mixture goes through the hopper as a fluid through a pipeline (a plug flow, Figure 3). Starting point is that no mixing takes place. This would mean that the model concentration is an average of the incoming concentration over a certain period of time (τ). When assuming a constant flow and mixture volume this is the time needed to fill this volume.

$$\tau = \frac{L}{s} = \frac{V_m}{Q} \quad \text{Eq. 11}$$

Second, one can assume uniform mixing (Figure 4) takes place (again neglecting any local processes and concentrations).

The total volume has to be divided into the volume of the sand bed (V_{bed}) and the volume of the mixture (V_m)

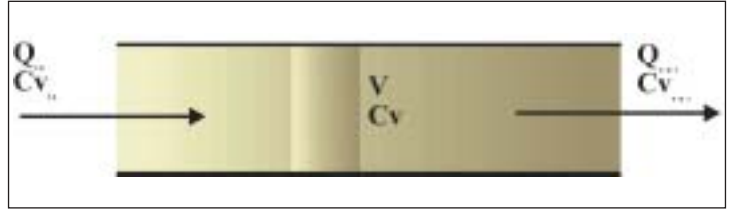
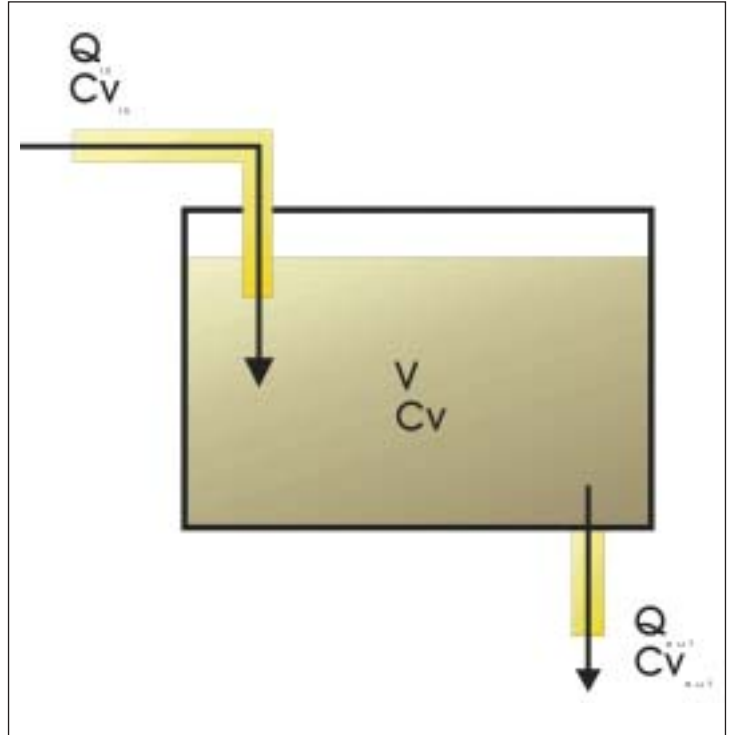

Figure 3. Plug flow.

Figure 4. Uniform Mixing.



in the hopper. Only the density of the bed (ρ_{bed}) can be assumed constant, the density of the mixture (ρ_m) changes in time and influences the settlement process.

$$\begin{aligned} \frac{dM(t)}{dt} &= Q_{in}(t) \cdot \rho_{in}(t) - Q_{out}(t) \cdot \rho_{out}(t) = \\ & \frac{\delta(V_{bed}(t) \cdot \rho_{bed})}{\delta t} + \frac{\delta(V_m(t) \cdot \rho_m(t))}{\delta t} \end{aligned} \quad \text{Eq. 12}$$

This partial differential equation has too many variables to be solved properly, without making assumptions about the increase in the bed volume and the overflow losses.

When introducing dynamics into the Camp model, not the exact concentration in the hopper but a dynamic substitute as input for the steady-state model has to be described. This means, we will not be looking for an actual average concentration but for a model concentration.

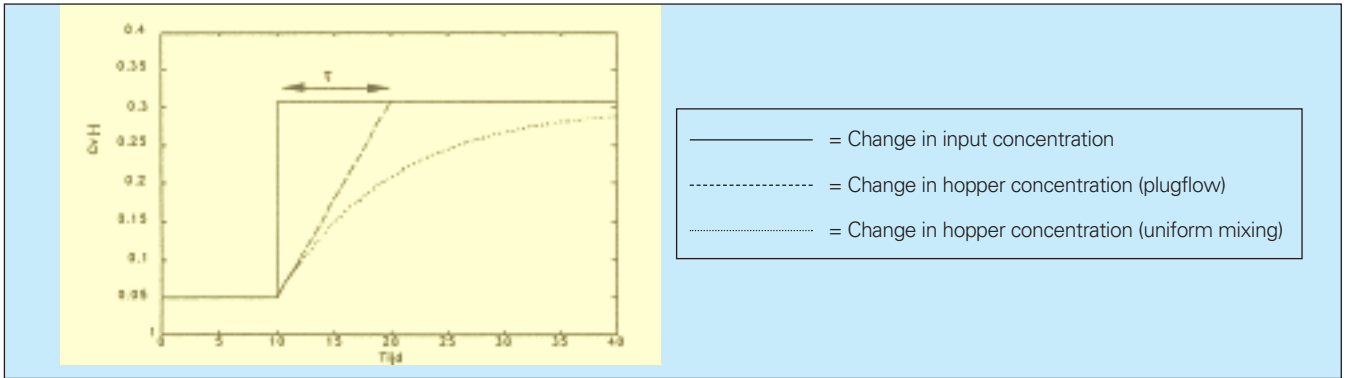

Figure 5. Step-response of a plugflow and a uniform mixing.

For the purpose of illustration and to get a better idea of the order of magnitude of the dynamics involved, one can neglect the change in the volume of the hopper and the volume of the bed, which simplifies the equation enormously and shows a basic description for uniform mixture (first order differential equation with a time constant equal to τ).

$$Cv_{in}(t) \cdot Q_{in}(t) - Cv_{out}(t) \cdot Q_{in}(t) = \frac{\delta (V_m \cdot Cv(t))}{\delta t} \quad \text{Eq. 13}$$

$$\begin{aligned} Cv_{out1} &= Cv \cdot ov \text{ (overflow loss),} \\ Cv_{out2} &= Cv \cdot (1-ov) \text{ (sedimentation),} \\ Cv_{out} &= Cv_{out1} + Cv_{out2} \end{aligned}$$

The fictive value for the concentration (Cv) in the hopper can be used as an input to the Camp model.

When calculating the fictive model concentration (Cv) based upon the idea of uniform mixing in a simulation, the change in volume of the mixture cannot be neglected and has to be estimated. Because of this change, the mixing process will accelerate.

With this description both input and process dynamics for the density can be described:

1. After reaching the overflow the flow in the hopper will change and thus the sedimentation and the density ("start value problem").
2. When changing the incoming concentration ("step response") (Figure 5).

Figure 6. Data for the calculations were logged on the TSDH Amsterdam.



A case study

To validate the theory, the dynamic relations and the Camp model were implemented in a simulation. Because the grain size distribution was not measured online, data were taken from the in-survey, which were representative over the whole dredging area (a $Cu (= d_{10}/d_{60})$ of 0.9 [-] and a d_{50} of 150 [μm]). The other data for the calculations were logged on the TSDH Amsterdam during loading.

Measured overflow losses

The measured overflow losses can be derived from the onboard measurement of the incoming concentration and flow and the change in the measured Tonnes Dry Solids.

$$ov = \frac{Cv_{in} \cdot Q_{in} \cdot \Delta t \cdot \rho_s - TDS(t) - TDS(t - \Delta t)}{Cv_{in} \cdot Q_{in} \cdot \Delta t \cdot \rho_s} \quad \text{Eq. 14}$$

As the result of this measurement is quite sensitive for noise on the measured signals, the measurement of the overflow losses was filtered.

Simulation and calculation of the overflow losses

The input for this simulation was the online measured concentration and flow and the step-time of the simulation was made equal to the sample period (Δt) of measurement. Other parameters like the efficient settling length and the concentration when the overflow is reached were estimated.

In the previous paragraphs the dynamics involved have been reduced to simple linear differential equations. In a simulation however non-linearities and more parameters can be introduced. The virtual model-density in the hopper now was calculated with the following numerical algorithm:

$$\rho_{m,corr} = \frac{\rho_{m,corr,old} \cdot (V_{mix} - Q_m \cdot \Delta t) + \rho_m \cdot Q_m \cdot \Delta t}{V_{mix}} \quad \text{Eq. 15}$$

The simulation starts with a start value ($\rho_{m,corr}$) for the density when the overflow is reached.

Figure 7. Calculated vs. measured overflow loss at trip 23 (case 1).

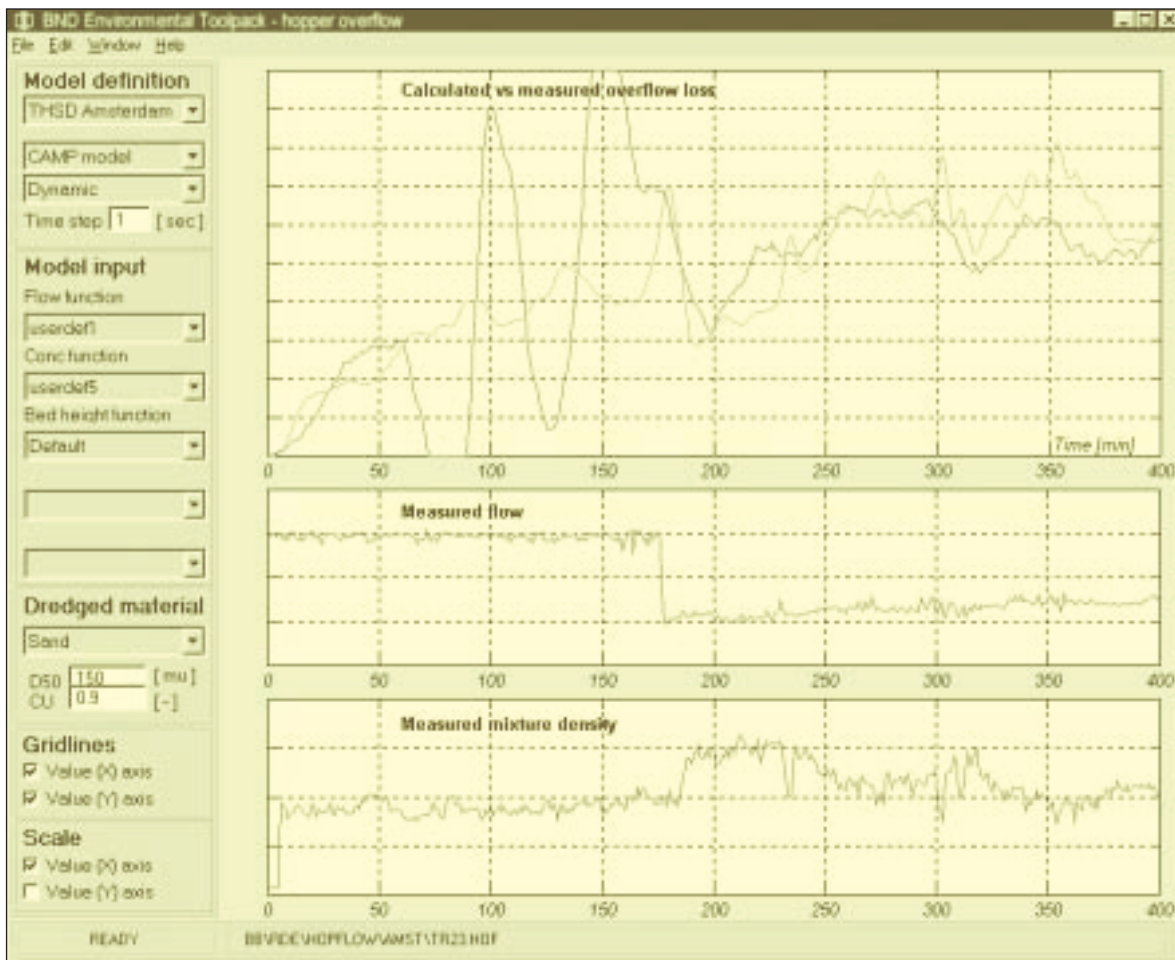

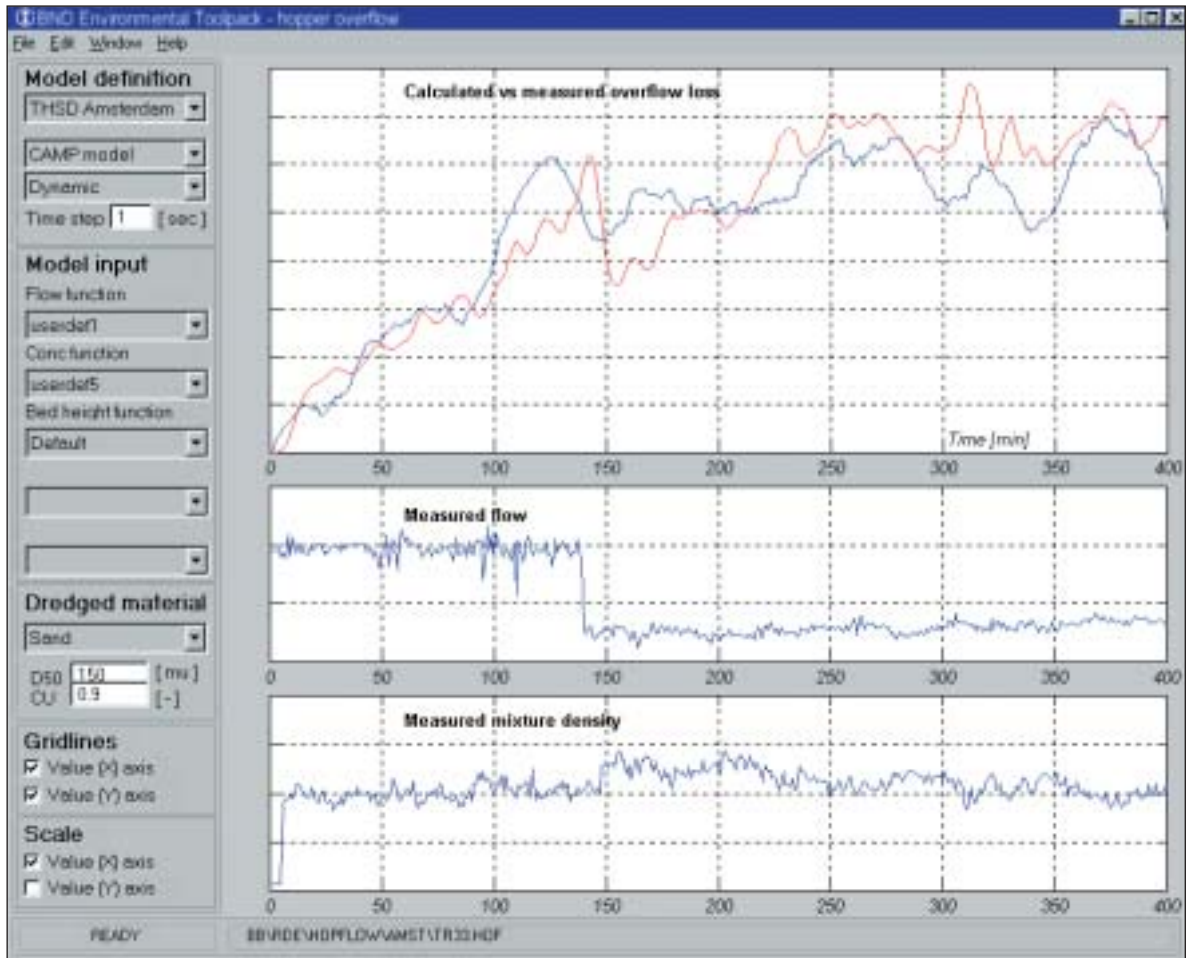

Figure 8. Calculated vs measured overflow losses at trip 33 (case 2).

The result of the static model is based on the fictive model concentration. The measured overflow losses however are described on the basis of the incoming concentration (Eq. 1). Therefore to be able to compare simulation with measurements calculated overflow losses become:

$$ov = \frac{C_v \cdot ov_{static}}{C_{v,in}} \quad \text{Eq. 16}$$

Comparison

In three situations the simulation was compared with the practice. All situations occurred with the same dredger and same type of sand. The figures show the overflow losses from the point the overflow has been reached onwards.

Case 1 (Figure 7): In the first situation the hopper starts loading with a high flow. After a certain period (at time step 180) the flow was reduced causing an increase in the concentration.

Between time step 70 and 170 a great error in the TDS signal occurred, but one still can distinguish the slow increase in the overflow losses when the overflow is

reached. When the flow was reduced at time step 180, the losses were reduced, but because of an increase in density the losses increased after a certain period.

Case 2 (Figure 8): In the second situation the flow was lowered at time-step 140, but in this case the density did not increase. This does not cause a step response in the overflow losses, owing to an increasing density.

Case 3 (Figure 9): In the last situation the hopper was loaded with a low flow until hopper was filled. In this trip an error in the measurements occurred at time step 170, nevertheless there seems to be a good correlation. Owing to the lower flow the average concentration in the hopper and thus the overflow losses increase slower (as can be concluded from equation 13).

After making a few assumptions, the model seems to show a good correlation (between 0.75 and 0.85) with the onboard data. Mainly the period of dynamics (defined as τ) seems to be correct. And the assumption the hopper works as a uniform mixing tank with a start value when the overflow is reached seems to fit and be right for both types of dynamics.

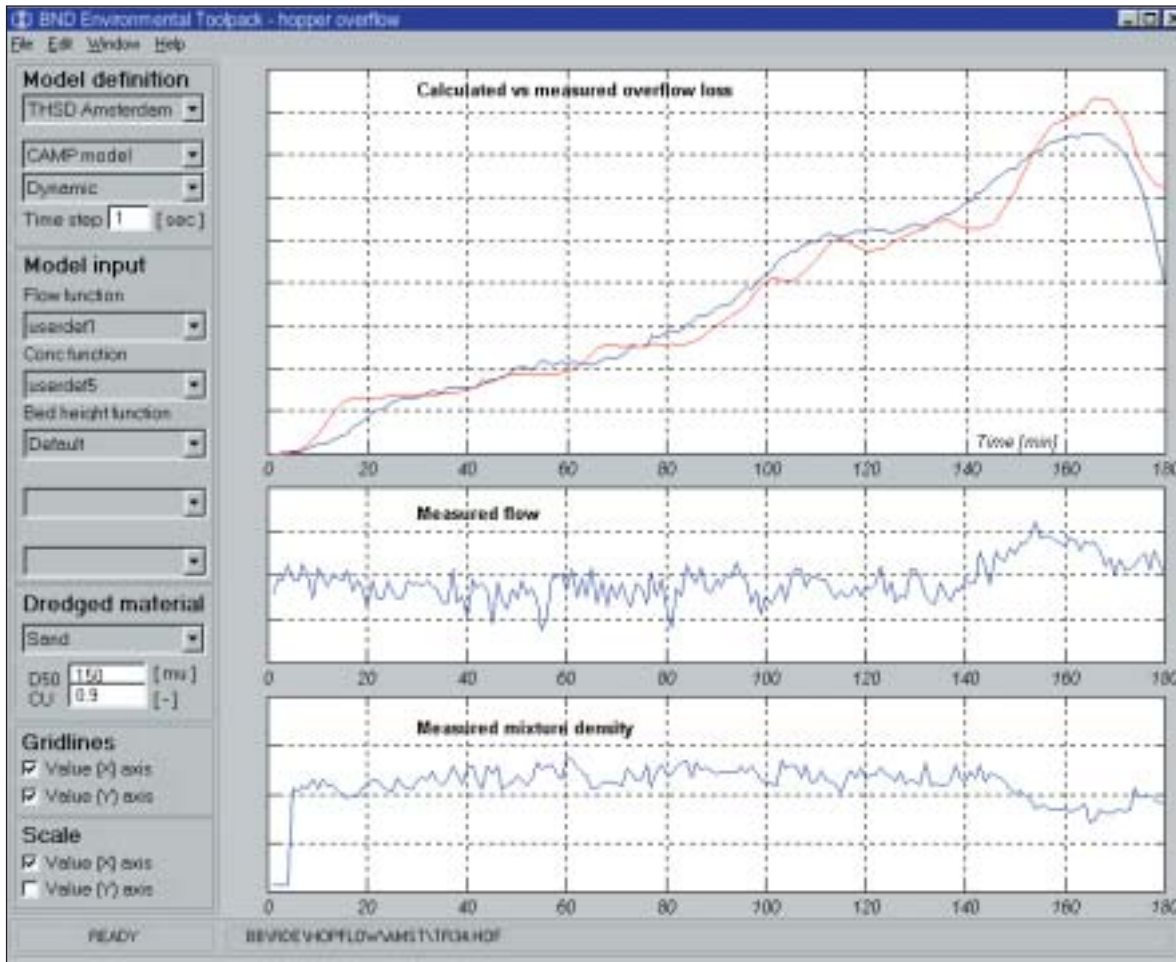

Figure 9. Calculated vs measured overflow at trip 34 (case 3).

Conclusions and Discussion

The aim of this article was to analyse and acknowledge the influence of dynamics in the hopper-loading process as part of the ongoing development in hopper settlement research. The dynamics of the concentration are a good reason for the changes in the overflow losses. Also changes in the flow play a part but seem to be of a higher frequency and a lower influence.

All local processes, like the local concentrations, were neglected and the hopper was modelled as a 'black box', which gave the possibility to implement the dynamics of the Camp model, using a virtual concentration as an input to the model. Despite this simplification the results gave a high correlation between model and measurement.

These dynamics are not only important for understanding the process and the influence of a change in a parameter during loading, but could be decisive when simulating and optimising the loading process.

As introducing dynamics in the settlement research

seems to be inevitable, the next steps have to be:

- a more detailed description of the dynamics;
- a description of local dynamics;
- making the Camp model itself dynamic.

References

1. Vlasblom, W.J. and Miedema, S.A.
"A theory for determining sedimentation and overflow losses".
Dredging Benefits: Proceedings of the Fourteenth World Dredging Congress, 1995: Vol. 1.
2. Ooijens S.C.
Modelleren van het sleepkop- en beunproces op sleepopperzuigers. Zeist: Ballast Nedam Dredging, 1999.